



## KIA SPORTAGE

01/2016 -

Cat. No. K/062

e20

e20\*94/20\*\*00

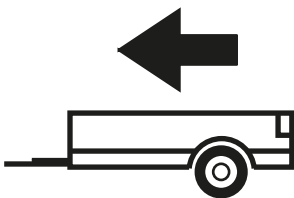

900Kg

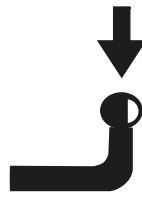

50Kg

**D** = 5,37kN

**D (kN) =**



MAX kg x MAX kg

x 0,00981



MAX kg + MAX kg

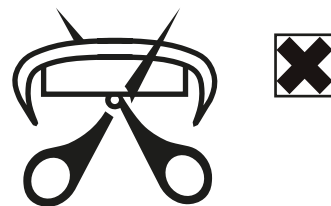
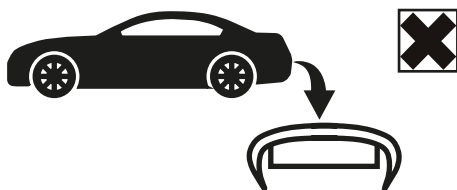

**IMIOLA HAK-POL**

96-111 KOWIESY, CHOJNATA 23A, POLAND

tel. +48 46 831 73 31, fax +48 831 74 29

e-mail: office@imiola.pl, www.imiola.pl

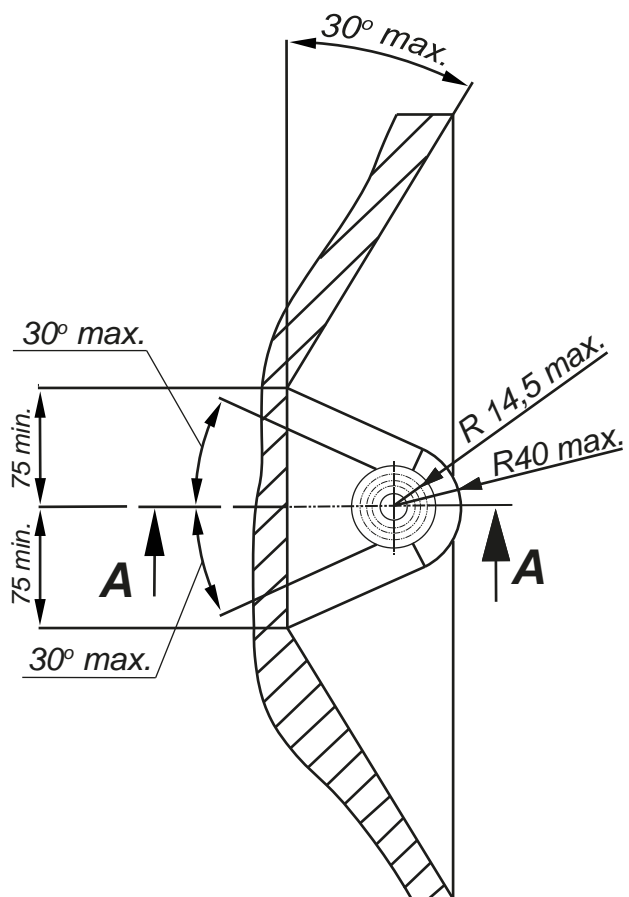

### PRZEKRÓJ A-A

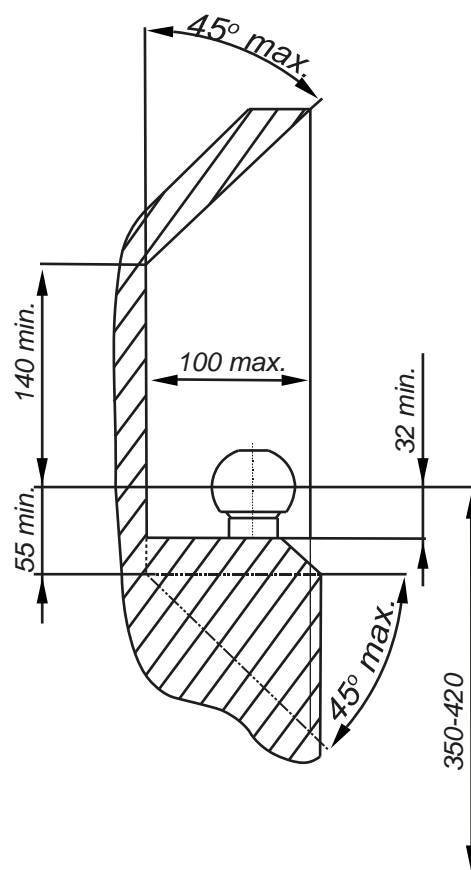

**PL** Należy zagwarantować przestrzeń swobodną według załącznika VII, rysunek 25a/b Regulaminu EKG ONZ 55.01 przy dopuszczalnym ciężarze całkowitym pojazdu.

**F** L'espace libre doit être garanti conformément à l'annexe VII, illustration de la réglementation 55.01 CE pour un poids total en charge autorisé du véhicule.

**GB** The clearance specified in appendix VII, diagram 25a/b of Regulation No. 55.01 UN EU must be guaranteed at laden weight of the vehicle.

**D** Der Freiraum nach Anhang VII, Abbildung 25a/b der Vorschriften 55.01 EG ist zu gew 25a/b abzugeben bei zulässigem Gesamtgewicht des Fahrzeuges.

Moment skręcający dla śrub i nakrętek (8.8) Torque settings for nuts and bolts (8.8)	
M8	25Nm
M10	55Nm
M12	85Nm
M14	135Nm
M16	195Nm

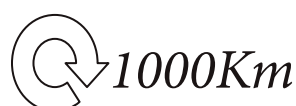

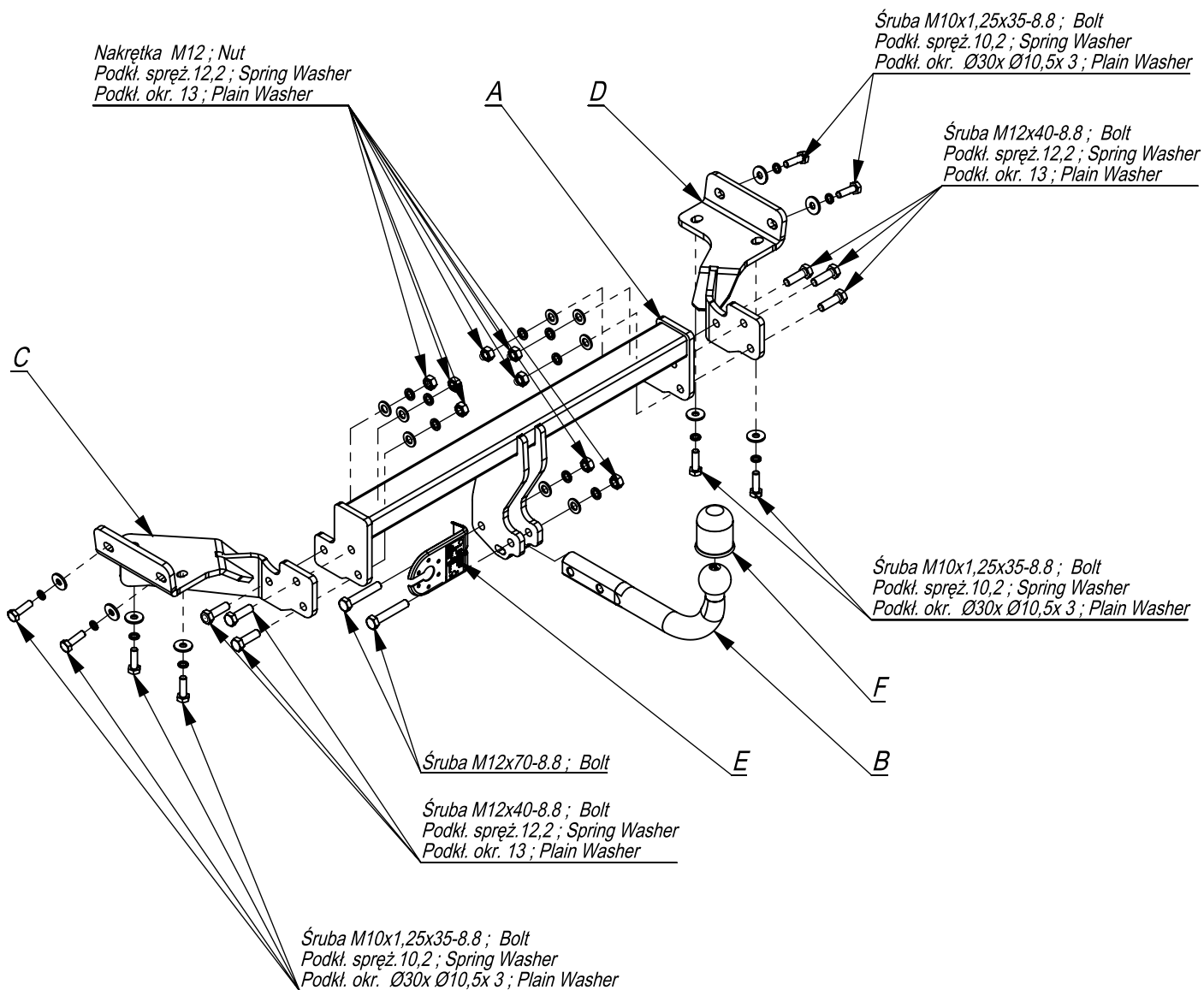

	A	x1		M12x70	2
				M12x40	6
				M10x1,25x35	8
	B	x1		M12	8
	C	x1		Ø30xØ10,5x3	8
	D	x1		13	8
	E	x1		12,2	8
	F	x1		10,2	8

Śruba M10x1,25x35-8.8 ; Bolt  
 Podkl. spręż. 10,2 ; Spring Washer  
 Podkl. okr. Ø30x Ø10,5x 3 ; Plain Washer

Śruba M12x40-8.8 ; Bolt  
 Podkl. spręż. 12,2 ; Spring Washer  
 Podkl. okr. 13 ; Plain Washer

Śruba M10x1,25x35-8.8 ; Bolt  
 Podkl. spręż. 10,2 ; Spring Washer  
 Podkl. okr. Ø30x Ø10,5x 3 ; Plain Washer

Nakrętka M12 ; Nut  
 Podkl. spręż. 12,2 ; Spring Washer  
 Podkl. okr. 13 ; Plain Washer

Śruba M12x40-8.8 ; Bolt  
 Podkl. spręż. 12,2 ; Spring Washer  
 Podkl. okr. 13 ; Plain Washer

Śruba M10x1,25x35-8.8 ; Bolt  
 Podkl. spręż. 10,2 ; Spring Washer  
 Podkl. okr. Ø30x Ø10,5x 3 ; Plain Washer

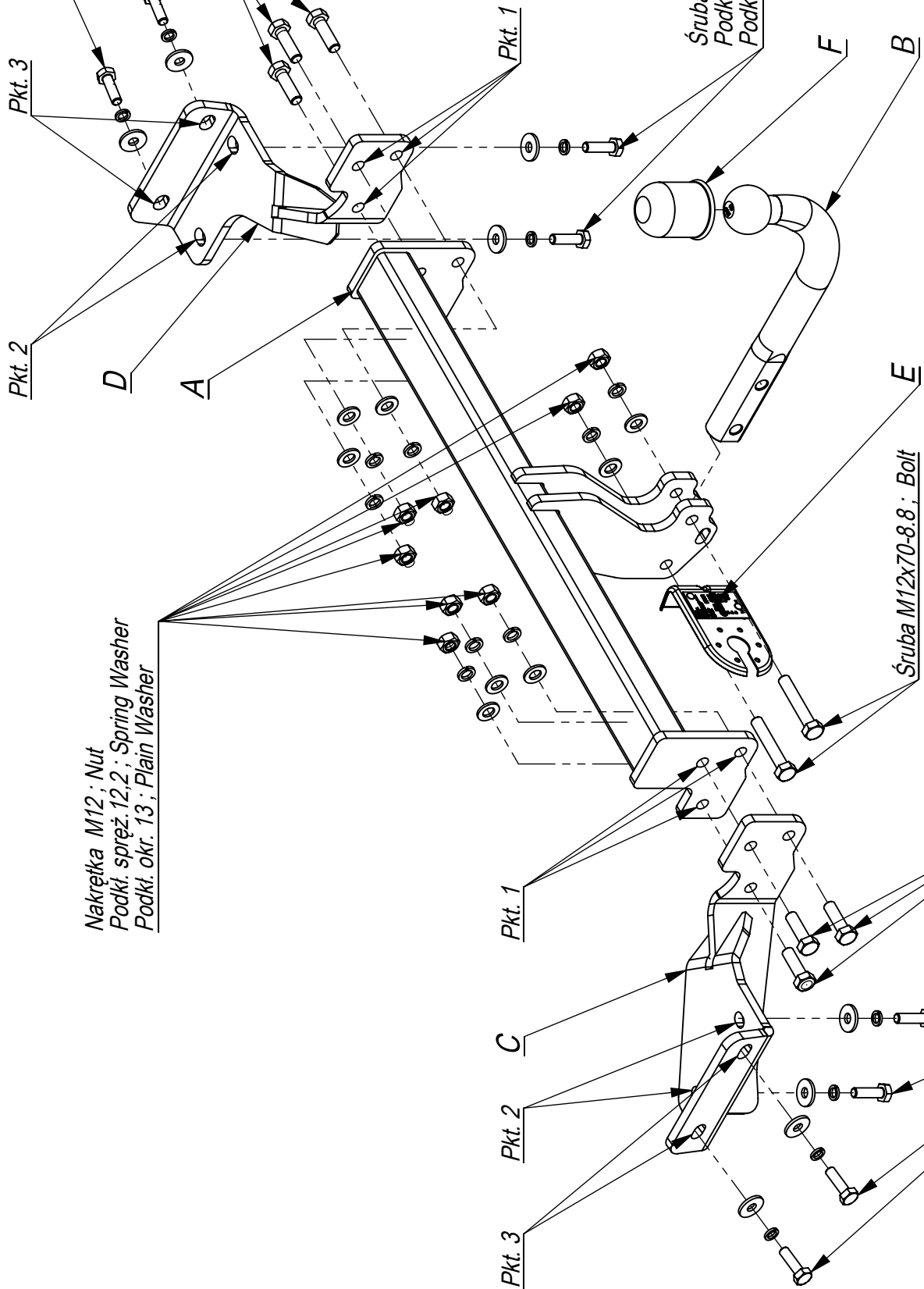

Nr katalogowy Marka  
 K/062 KIA Sportage

od 01/2016 ->

96-111 Kowiesy, Chojnata 23 A  
 tel. +48 46 831 73 31

- Odkręcić tłumik i osłony.
- Przykręcić elementy C i D do podłużnic śrubami M10x1,25x35 8.8 (pkt 2 i 3).
- Do elementów C i D przykręcić belkę A śrubami M12x40 8.8 (pkt 1).
- Przykręcić tłumik i osłony.
- Dokręcić wszystkie śruby z momentem wg tabeli.
- Podłączyć instalację elektryczną.
- Dokręcić kulę i blachę gniazda elektrycznego.

- Unscrew the muffler and shields.
- Screw the elements C and D to the frame side members with bolts M10x1,25x35 8.8 (point 2 and 3).
- Screw the main bar A to the elements C and D with bolts M12x40 8.8 (point 1).
- Screw the muffler and shields.
- Tighten all the bolts according to the torque setting- see the table.
- Connect the electric wires.
- Fix the ball and electric plate.

- Dévisser le pot d'échappement et les protections.
- Serrer les éléments C et D aux longerons à l'aide de boulons M10x1,25x35 8.8 (pts 2 et 3).
- Serrer la barre A aux éléments C et D à l'aide de boulons M12x40 8.8 (pt 1).
- Visser le pot d'échappement et les protections.
- Serrer tous les boulons avec un couple de serrage selon tableau.
- Raccorder le circuit électrique.
- Visser le crochet d'attelage et le socle de prise électrique.

