



2006 -

KIA CEE'D htb.

Cat. No. **K/021**

e20

e20\*94/20\*0860\*00





1500Kg



75Kg

**D = 8,30kN**

$$D \text{ (kN)} = \frac{\text{MAX kg} \times \text{MAX kg}}{\text{MAX kg} + \text{MAX kg}} \times 0,00981$$





**IMIOLA HAK-POL**

96-111 KOWIESY, CHOJNATA 23A, POLAND

tel. +48 46 831 73 31, fax +48 831 74 29

e-mail: office@imiola.pl, www.imiola.pl

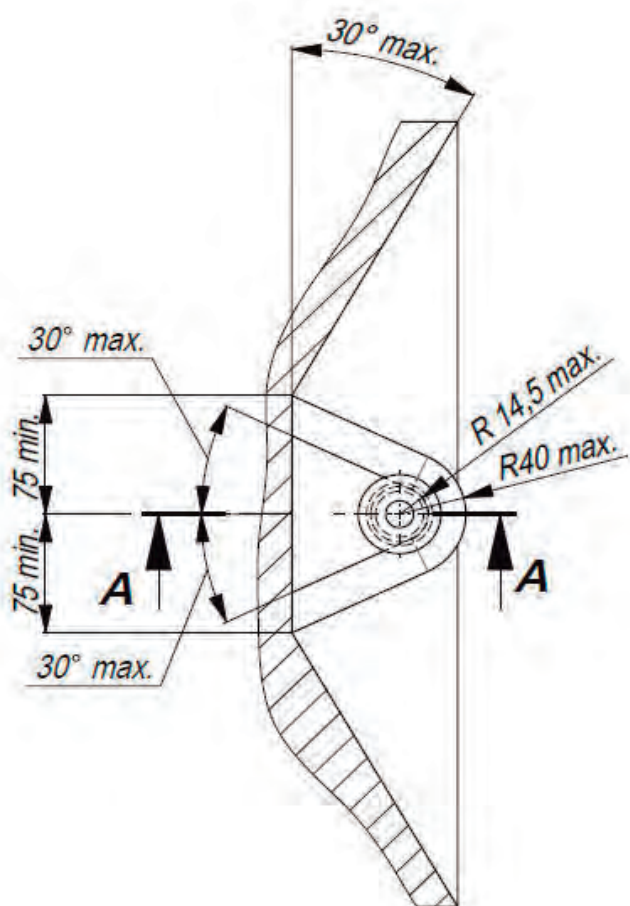

PRZEKRÓJ A-A

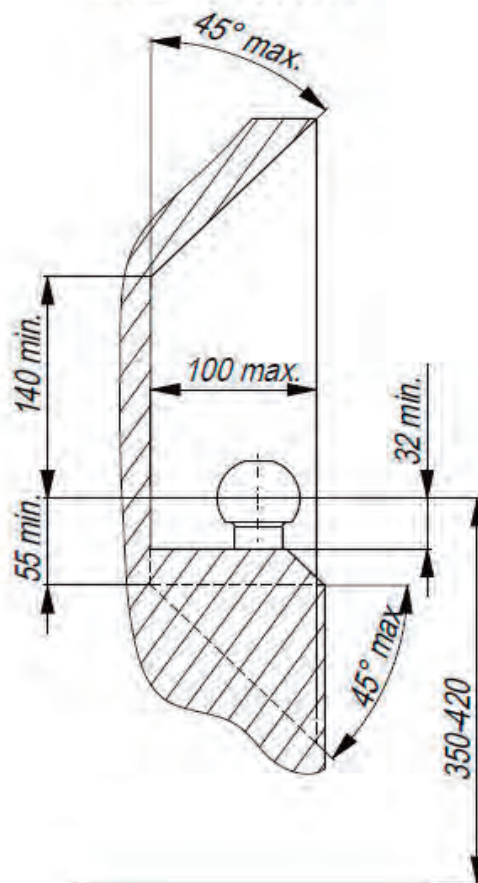

**PL** Należy zagwarantować przestrzeń swobodną według załącznika VII, rysunek 25a/b Regulaminu EKG ONZ 55.01 przy dopuszczalnym ciężarze całkowitym pojazdu.

**F** L'espace libre doit être garanti conformément à l'annexe VII, illustration de la réglementation 55.01 CE pour un poids total en charge autorisé du véhicule.









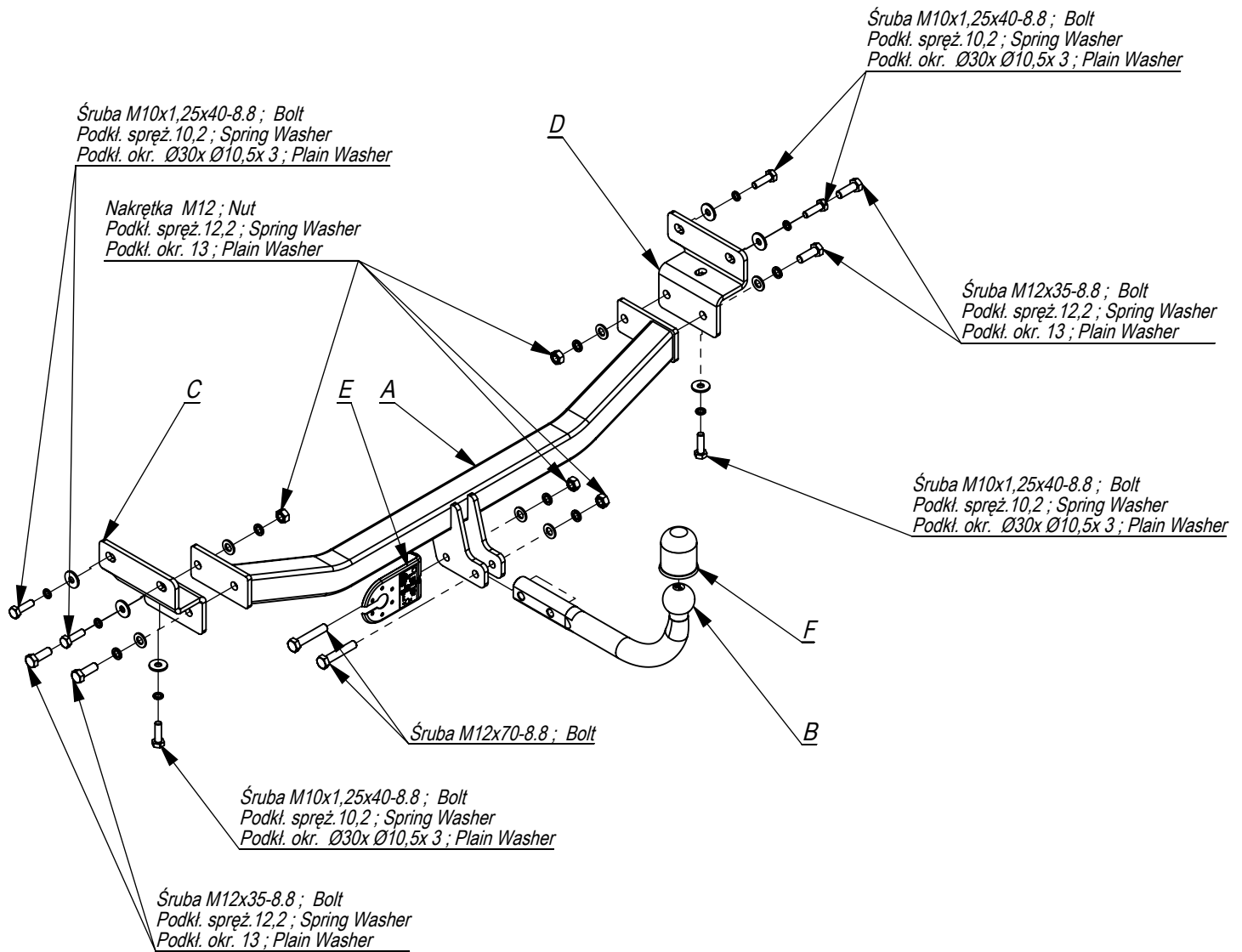

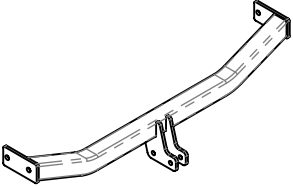
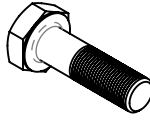
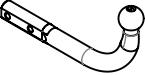

**GB** The clearance specified in appendix VII, diagram 25a/b of Regulation No. 55.01 UN EU must be guaranteed at laden weight of the vehicle.

**D** Der Freiraum nach Anhang VII, Abbildung 25a/b der Vorschriften 55.01 EG ist zu gew 25a/b abzuhalten bei zulässigem Gesamtgewicht des Fahrzeuges

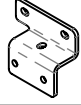
Moment skracający dla śrub i nakrętek (8.8) Torgue settings for nuts and bolts (8.8)	
M8	25Nm
M10	55Nm
M12	85Nm
M14	135Nm
M16	195Nm





	A	x1		M12x70	2
				M12x35	4
				M10x1,25x40	6
	B	x1		M12	4
					Ø30xØ10,5x3
	C	x1		13	6
					12,2
	D	x1		10,2	6
					10,2
	E	x1		12,2	6
					10,2
	F	x1			

Śruba M10x1,25x40-8.8 ; Bolt  
 Podkl. spręż. 10,2 ; Spring Washer  
 Podkl. okr. Ø30x Ø10,5x 3 ; Plain Washer

Śruba M12x35-8.8 ; Bolt  
 Podkl. spręż. 12,2 ; Spring Washer  
 Podkl. okr. 13 ; Plain Washer

Śruba M10x1,25x40-8.8 ; Bolt  
 Podkl. spręż. 10,2 ; Spring Washer  
 Podkl. okr. Ø30x Ø10,5x 3 ; Plain Washer

Pkt. 2

Pkt. 1

D

Pkt. 3

Śruba M10x1,25x40-8.8 ; Bolt  
 Podkl. spręż. 10,2 ; Spring Washer  
 Podkl. okr. Ø30x Ø10,5x 3 ; Plain Washer

Nakrętka M12 ; Nut  
 Podkl. spręż. 12,2 ; Spring Washer  
 Podkl. okr. 13 ; Plain Washer

C

Pkt. 1

E

A

Śruba M12x70-8.8 ; Bolt

Pkt. 3

Pkt. 2

Śruba M10x1,25x40-8.8 ; Bolt  
 Podkl. spręż. 10,2 ; Spring Washer  
 Podkl. okr. Ø30x Ø10,5x 3 ; Plain Washer

Śruba M12x35-8.8 ; Bolt  
 Podkl. spręż. 12,2 ; Spring Washer  
 Podkl. okr. 13 ; Plain Washer

F

B

Pkt. 2

Pkt. 1

Nr katalogowy  
**K1021**

Marka

KIA Ceed' htb. od 2006 ->



96-111 Kowiesy, Chojnata 23 A  
 tel. +48 46 831 73 31



- Odkręcić plastikowe osłony podłużnic.
- Opuścić tłumik.
- Udostępnić technologiczne otwory z gwintami w podłużnicach.
- Przykręcić elementy C i D do podłużnic śrubami M12x35x1,25 wg rys. (pkt 1, 2).
- Do elementów C i D przykręcić belkę zaczepu A śrubami M12x35 8.8 (pkt 3).
- Dokręcić wszystkie śruby z momentem wg tabeli.
- Wykonać wycięcia w plastikowych osłonach podłużnic, a następnie przykręcić je.
- Założyć tłumik.
- Przykręcić kulę i blachę gniazda elektrycznego.
- Podłączyć instalację elektryczną.

- Unscrew the plastic shields of the metal clamps.
- Lower the damper.
- The technological holes with threads in the metal clamps make permeable.
- Screw the elements C and D to the metal clamps with bolts M12x35x1,25, according to the drawing (point 1, 2).
- Screw the main bar A to the elements C and D with bolts M12x35 8.8 (point 3).
- Tighten all the bolts according to the torque setting- see the table.
- Make an openings in the plastic shields of the metal clamps and next screw them.
- Hang the damper.
- Fix the ball and electric plate.
- Connect the electric wires.

- Desserrer les carters en plastiques de longerons.
- Abaisser le silencieux.
- Déboucher les trous technologiques avec le filetage dans les longerons.
- Visser les éléments C et D aux longerons, en utilisant les boulons M12x35x1,25 selon le dessin (point 1, 2).
- Visser la poutre du crochet A aux éléments C et D à l'aide des boulons M12x35 8.8 (point 3).
- Serrer tous les boulons avec un couple de serrage selon tableau.
- Faire une coupe dans les carters plastiques des longerons et ensuite les serrer.
- Monter le silencieux.
- Visser la boule et socle de prise électrique.
- Raccorder le circuit électrique.

