



MERCEDES C-KLASA (W-205)  
 MERCEDES C-KLASA (S-205)

02.2014 -  
 09.2014 -

Cat. No. M/047

e20

e20\*94/20\*\*00

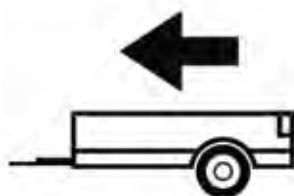

2150Kg



75Kg

**D** = 10,50kN

**D (kN) =**



MAX kg

x

MAX kg

x 0,00981



MAX kg

+

MAX kg



**IMIOLA HAK-POL**

96-111 KOWIESY, CHOJNATA 23A, POLAND

tel. +48 46 831 73 31, fax +48 831 74 29

e-mail: office@imiola.pl, www.imiola.pl

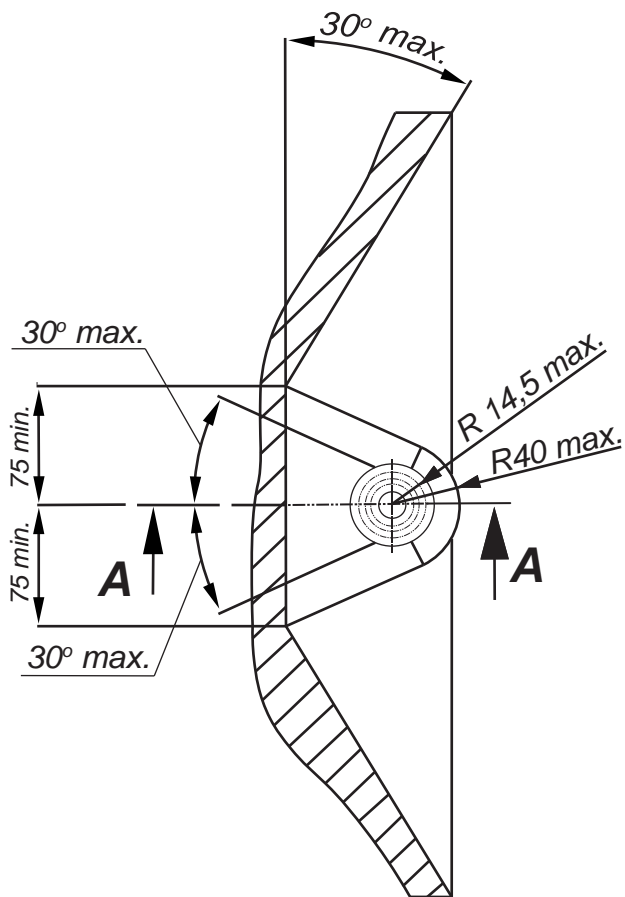

### PRZEKRÓJ A-A

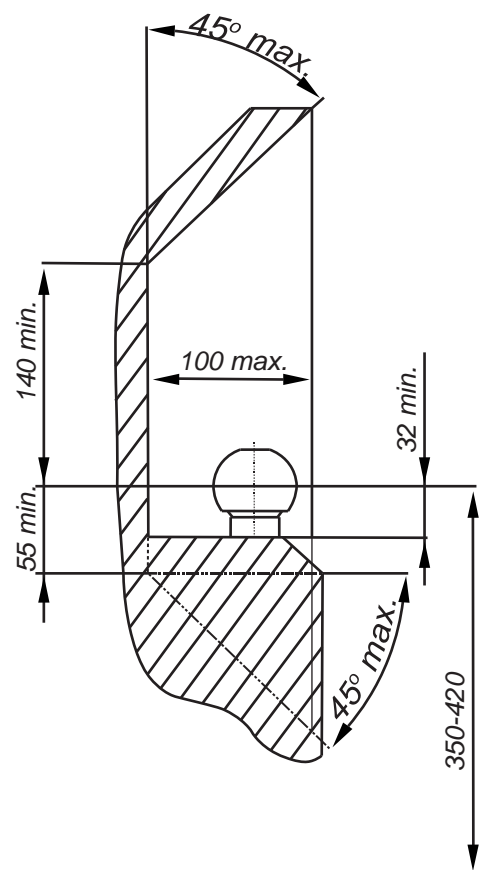

**PL** Należy zagwarantować przestrzeń swobodną według załącznika VII, rysunek 25a/b Regulaminu EKG ONZ 55.01 przy dopuszczalnym ciężarze całkowitym pojazdu.

**F** L'espace libre doit être garanti conformément à l'annexe VII, illustration de la réglementation 55.01 CE pour un poids total en charge autorisé du véhicule.







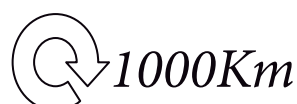

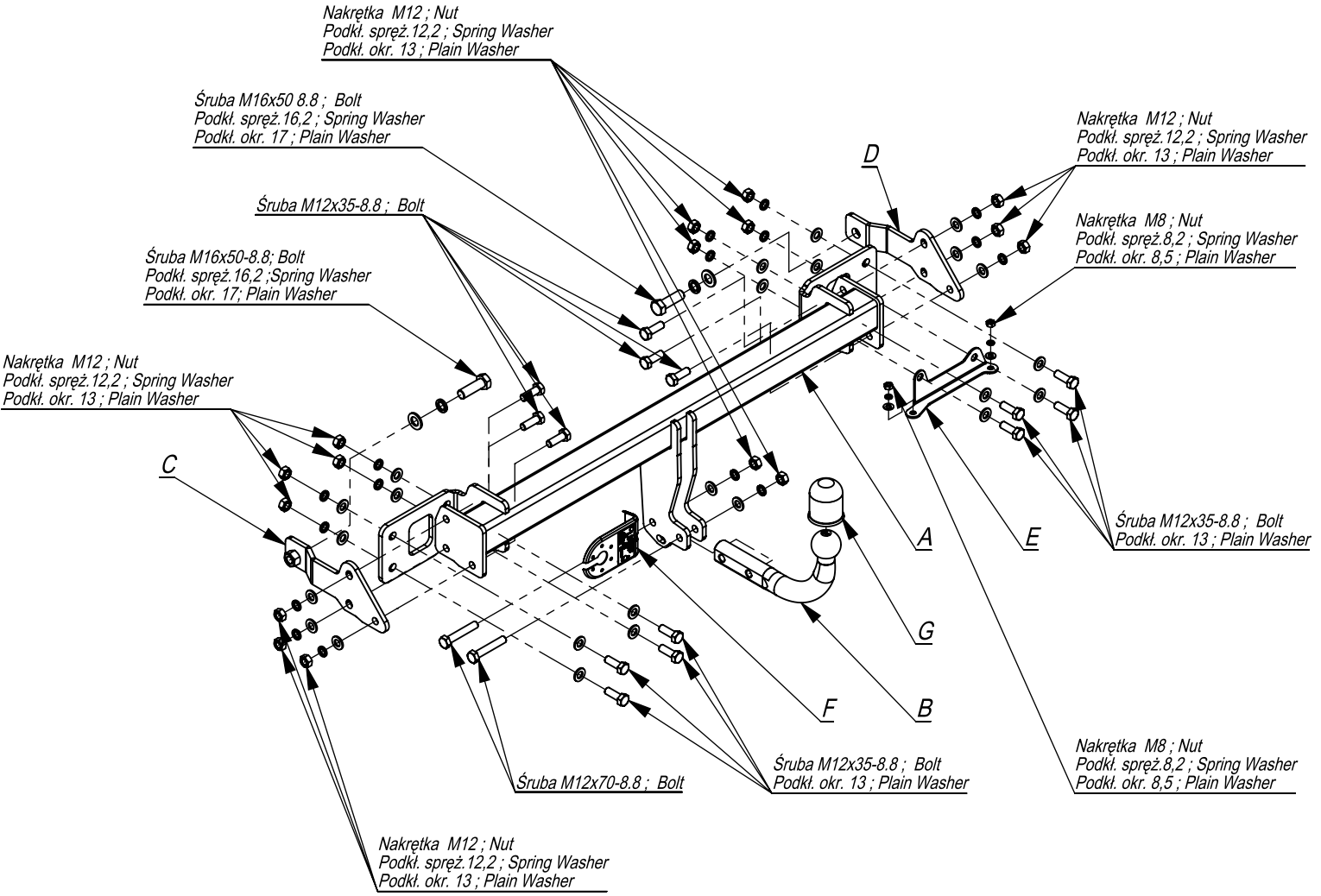
**GB** The clearance specified in appendix VII, diagram 25a/b of Regulation No. 55.01 UN EU must be guaranteed at laden weight of the vehicle.

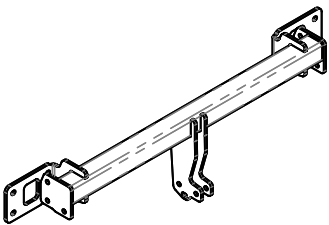
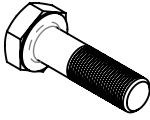
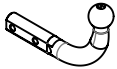
**D** Der Freiraum nach Anhang VII, Abbildung 25a/b der Vorschriften 55.01 EG ist zu gew 25a/b abzuhalten bei zulässigem Gesamtgewicht des Fahrzeuges.

Moment skracający dla śrub i nakrętek (8.8) Torque settings for nuts and bolts (8.8)	
M8	25Nm
M10	55Nm
M12	85Nm
M14	135Nm
M16	195Nm

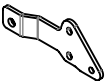



	A	x1		M16x50	2
				M12x70	2
				M12x35	14
	B	x1		M12	16
				M8	2
	C	x1		13	22
				8,5	2
	D	x1		12,2	16
				8,2	2
	E	x1			
	F	x1			
	G	x1			

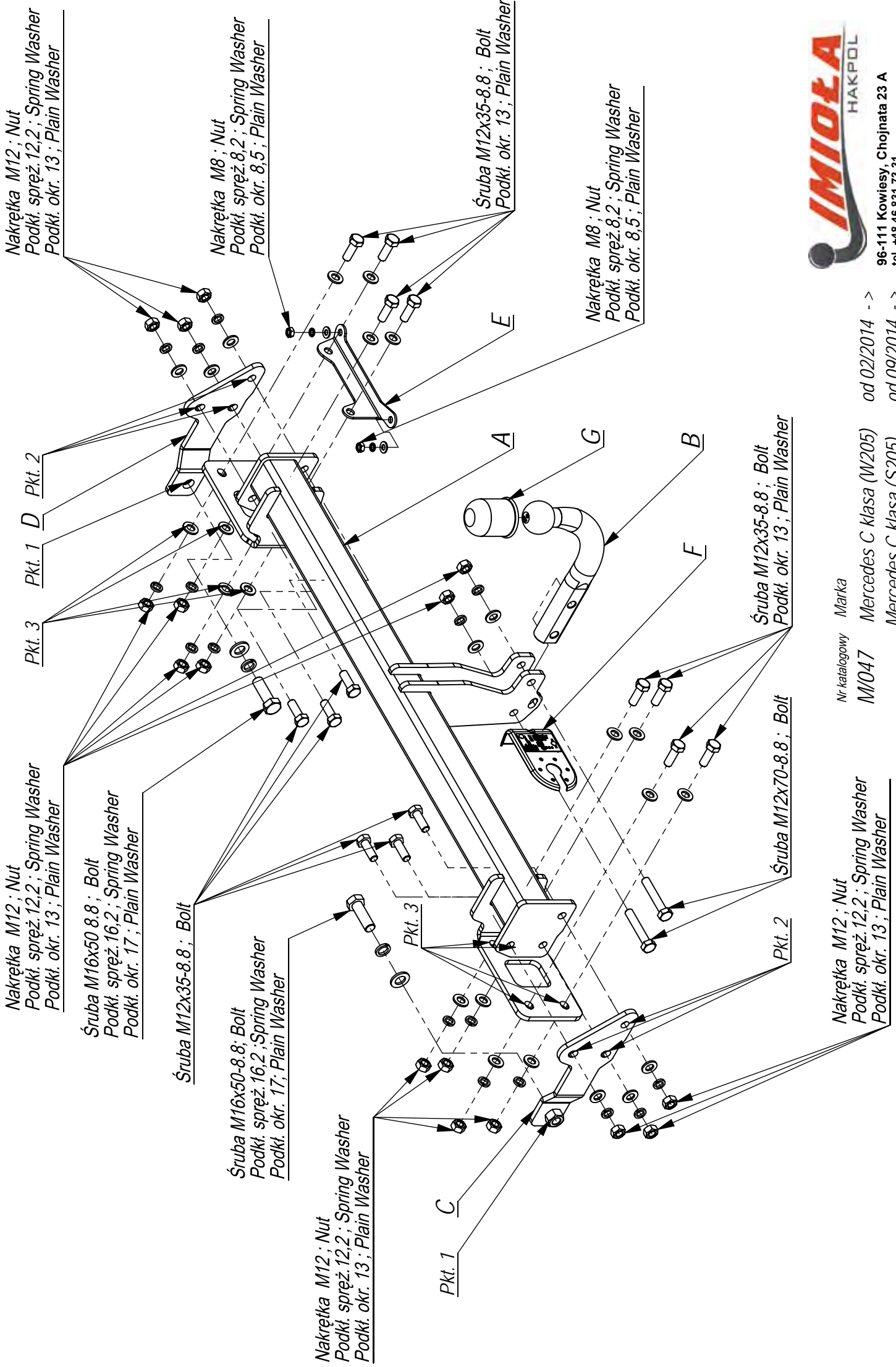

96-111 Kowiesy, Chojnata 23 A  
tel. +48 46 831 73 31

Nr katalogowy Marka

M1047

Mercedes C klasa (W205)

od 02/2014 ->

Mercedes C klasa (S205)

od 09/2014 ->

Nakrętka M12; Nut

Podkł. spręż. 12,2; Spring Washer

Podkł. okr. 13; Plain Washer

Śruba M12x35-8.8; Bolt

Podkł. okr. 13; Plain Washer

Śruba M12x70-8.8; Bolt

Podkł. okr. 13; Plain Washer

- Odkręcić zderzak i metalowe wzmocnienie (nie będzie już ponownie montowane).
- Wsporniki C wsunąć w podłużnice i poprzez technologiczne otwory w bokach podłużnic przykręcić lekko śrubami M16x50 8.8 (pkt 1).
- Belkę zaczepu A przykręcić do tylnego pasa samochodu śrubami M12x35 8.8 (pkt 3) oraz do elementów C śrubami M12x35 8.8 (pkt 2). Element haka E przykręcić do belki A w części prawej wg rys.
- Dokręcić wszystkie śruby z momentem wg tabeli.
- Zamontować zderzak.
- Podłączyć instalację elektryczną.
- Przykręcić kulę i blachę gniazda elektrycznego.

