



2002 -

FORD FUSION

Cat. No. **E/034**

e20

e20*94/20*0944*00

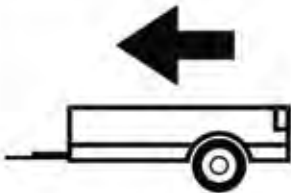

1050Kg



50Kg

D = 6,50kN

D (kN) = $\frac{\text{MAX kg} \times \text{MAX kg}}{\text{MAX kg} + \text{MAX kg}} \times 0,00981$

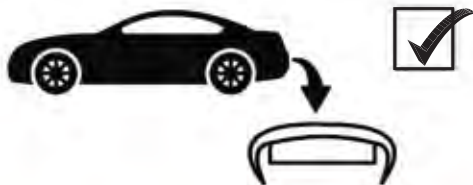

IMIOLA HAK-POL

96-111 KOWIESY, CHOJNATA 23A, POLAND

tel. +48 46 831 73 31, fax +48 831 74 29

e-mail: office@imiola.pl, www.imiola.pl

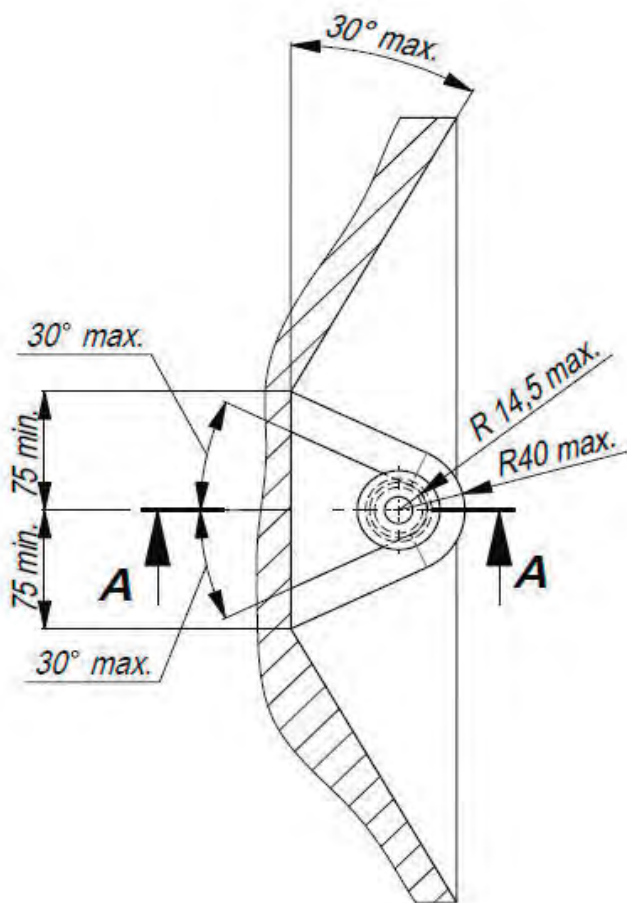

PRZEKRÓJ A-A

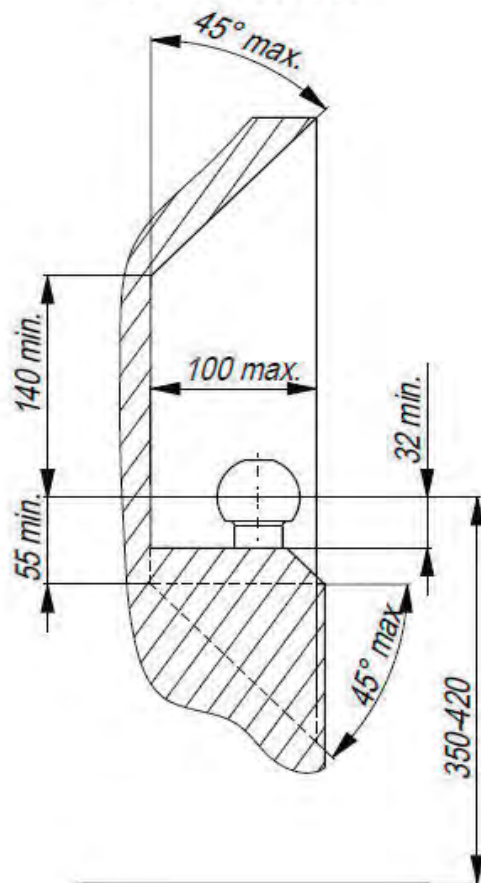

PL Należy zagwarantować przestrzeń swobodną według załącznika VII, rysunek 25a/b Regulaminu EKG ONZ 55.01 przy dopuszczalnym ciężarze całkowitym pojazdu.

F L'espace libre doit être garanti conformément à l'annexe VII, illustration de la réglementation 55.01 CE pour un poids total en charge autorisé du véhicule.





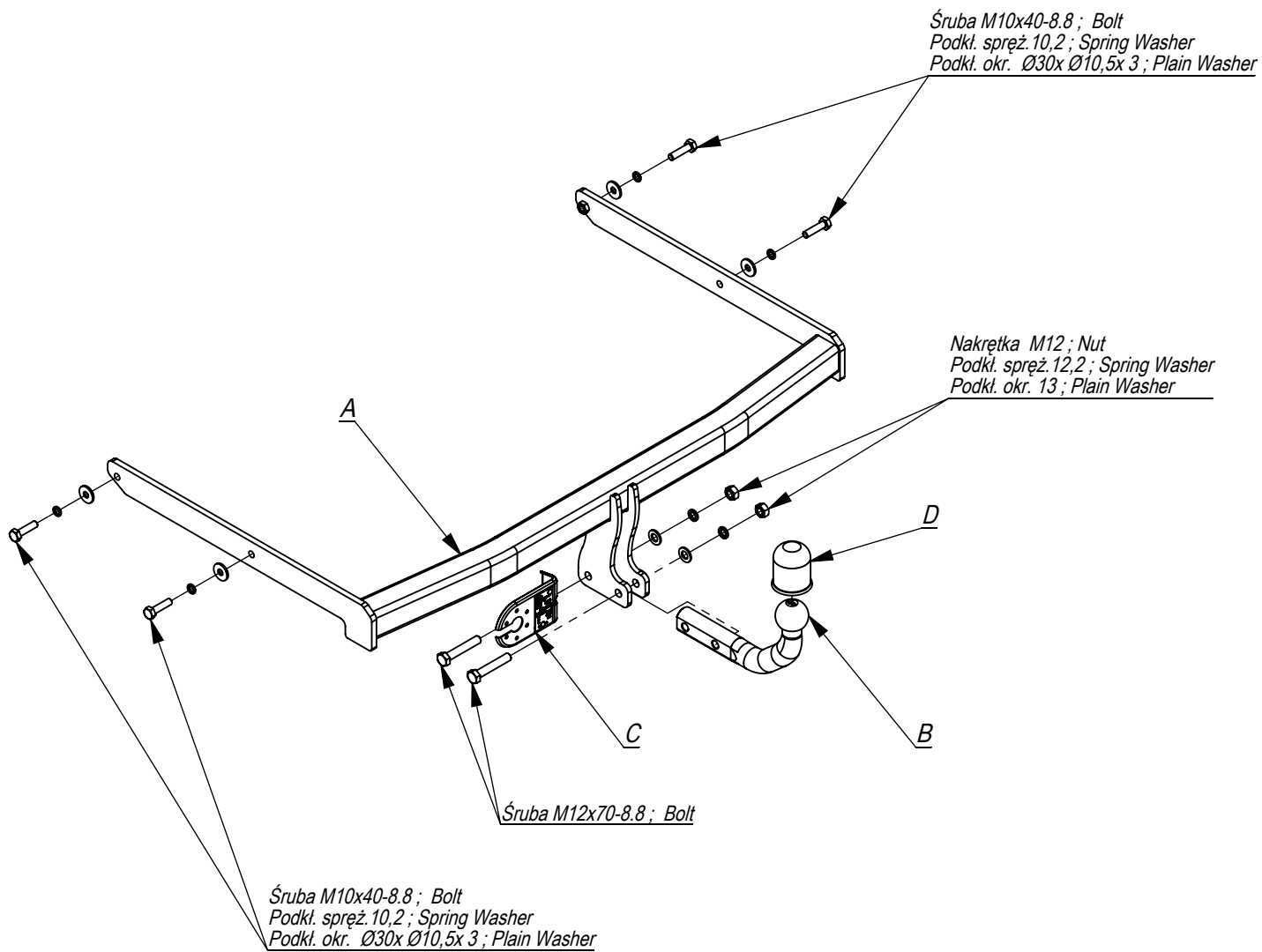

GB The clearance specified in appendix VII, diagram 25a/b of Regulation No. 55.01 UN EU must be guaranteed at laden weight of the vehicle.

D Der Freiraum nach Anhang VII, Abbildung 25a/b der Vorschriften 55.01 EG ist zu gew 25a/b abzuwehren bei zulässigem Gesamtgewicht des Fahrzeuges

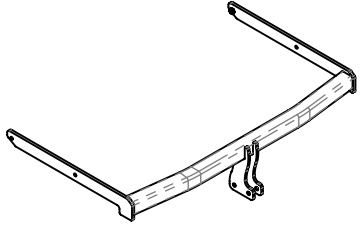
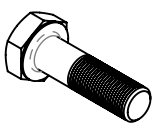
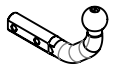
Moment skręcający dla śrub i nakrętek (8.8) Torgue settings for nuts and bolts (8.8)	
M8	25Nm
M10	55Nm
M12	85Nm
M14	135Nm
M16	195Nm





	A	x1		M12x70	2
				M10x40	4
	B	x1		M12	2
	C	x1		Ø30xØ10,5x3	4
	D	x1		13	2
				12,2	2
				10,2	4

Śruba M10x40-8.8 ; Bolt
Podkl. spręż. 10,2 ; Spring Washer
Podkl. okr. Ø30x Ø10,5x 3 ; Plain Washer

Nakrętka M12 ; Nut
Podkl. spręż. 12,2 ; Spring Washer
Podkl. okr. 13 ; Plain Washer

Śruba M10x40-8.8 ; Bolt
Podkl. spręż. 10,2 ; Spring Washer
Podkl. okr. Ø30x Ø10,5x 3 ; Plain Washer

Śruba M12x70-8.8 ; Bolt

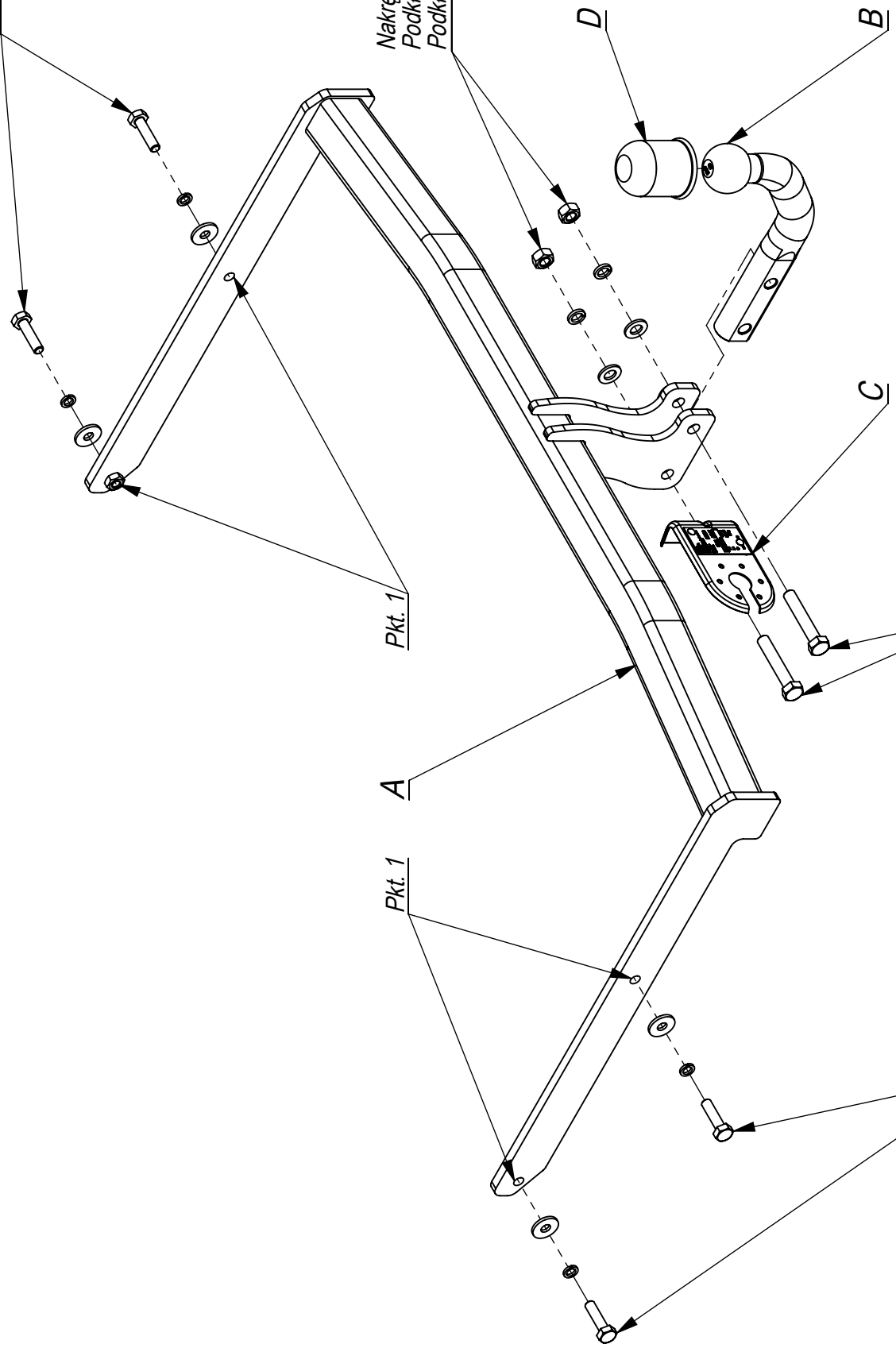

Nr katalogowy
E/034

Marka
Ford Fusion od 2002 ->



96-111 Kowiesy, Chojnata 23 A
tel. +48 46 831 73 31

- Odkręcić zderzak.
- Wsunąć belkę haka do podłużnic. Poprzez technologiczne otwory w bokach podłużnic przykręcić śrubami M10x40 8.8.
- Zamontować zderzak.
- Przykręcić kulę i blachę gniazda elektrycznego śrubami M12x70 8.8.
- Podłączyć instalację elektryczną.
- Dokręcić wszystkie śruby z momentem wg tabeli.

- Unscrew the bumper.
- Insert the main bar in the metal clamps. Screw with bolts M10x40 8.8, through the technological holes in the sides of the metal clamps.
- Screw the bumper.
- Fix the ball and electric plate with bolts M12x70 8.8.
- Connect the electric wires.
- Tighten all the bolts according to the torque setting- see the table.

