



HYUNDAI ix 35  
KIA SPORTAGE

08.2010 -

Cat. No. J/038

e20

e20\*94/20\*1333\*00

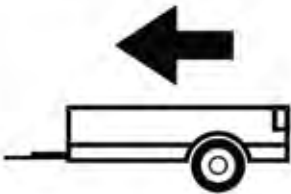

2000Kg



80Kg

**D = 10,14kN**

**D (kN) =**  $\frac{\text{MAX kg} \times \text{MAX kg}}{\text{MAX kg} + \text{MAX kg}} \times 0,00981$



**IMIOLA HAK-POL**

96-111 KOWIESY, CHOJNATA 23A, POLAND

tel. +48 46 831 73 31, fax +48 831 74 29

e-mail: office@imiola.pl, www.imiola.pl

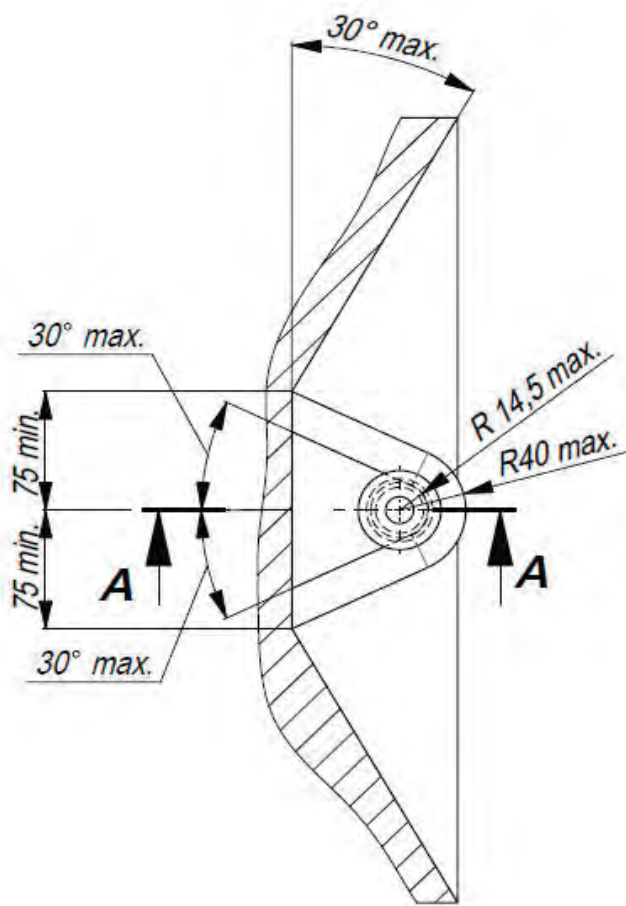

PRZEKRÓJ A-A

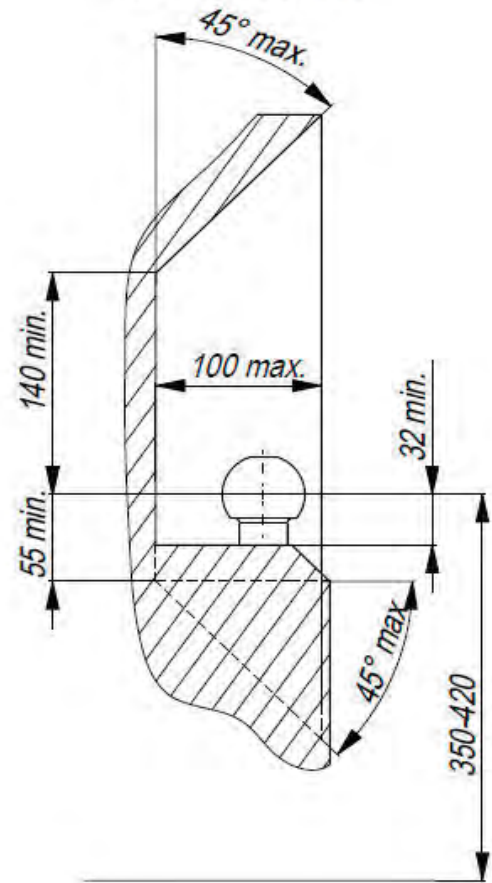

**PL** Należy zagwarantować przestrzeń swobodną według załącznika VII, rysunek 25a/b Regulaminu EKG ONZ 55.01 przy dopuszczalnym ciężarze całkowitym pojazdu.

**GB** The clearance specified in appendix VII, diagram 25a/b of Regulation No. 55.01 UN EU must be guaranteed at laden weight of the vehicle.

**F** L'espace libre doit être garanti conformément à l'annexe VII, illustration de la réglementation 55.01 CE pour un poids total en charge autorisé du véhicule.

**D** Der Freiraum nach Anhang VII, Abbildung 25a/b der Vorschriften 55.01 EG ist zu gew 25a/b abzuwehren bei zulässigem Gesamtgewicht des Fahrzeuges

**Moment skrecający dla śrub i nakrętek (8.8)**  
**Torque settings for nuts and bolts (8.8)**

<b>M8</b>	<b>25Nm</b>
<b>M10</b>	<b>55Nm</b>
<b>M12</b>	<b>85Nm</b>
<b>M14</b>	<b>135Nm</b>
<b>M16</b>	<b>195Nm</b>

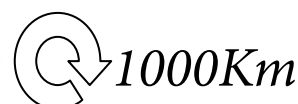

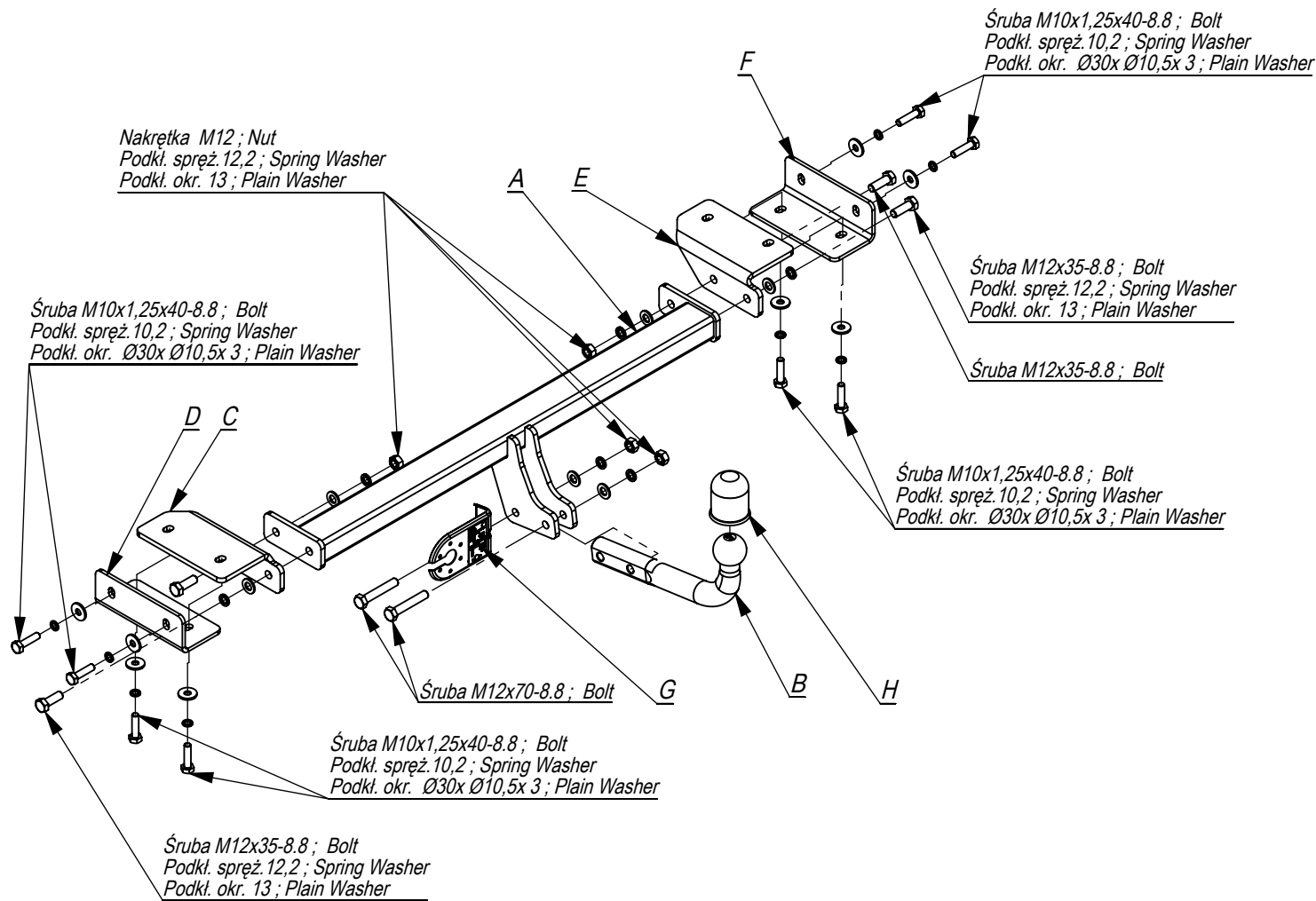

	A	x1		M12x70	2
				M12x35	4
				M10x1,25x40	8
	B	x1		M12	4
	C	x1		Ø30xØ10,5x3	8
	D	x1		13	6
	E	x1		12,2	6
	F	x1		10,2	8
	G	x1			
	H	x1			

Śruba M10x1,25x40-8.8 ; Bolt  
Podkl. spręż. 10,2 ; Spring Washer  
Podkl. okr. Ø30x Ø10,5x 3 ; Plain Washer

Śruba M12x35-8.8 ; Bolt  
Podkl. spręż. 12,2 ; Spring Washer  
Podkl. okr. 13 ; Plain Washer

Śruba M12x35-8.8 ; Bolt

Śruba M10x1,25x40-8.8 ; Bolt  
Podkl. spręż. 10,2 ; Spring Washer  
Podkl. okr. Ø30x Ø10,5x 3 ; Plain Washer

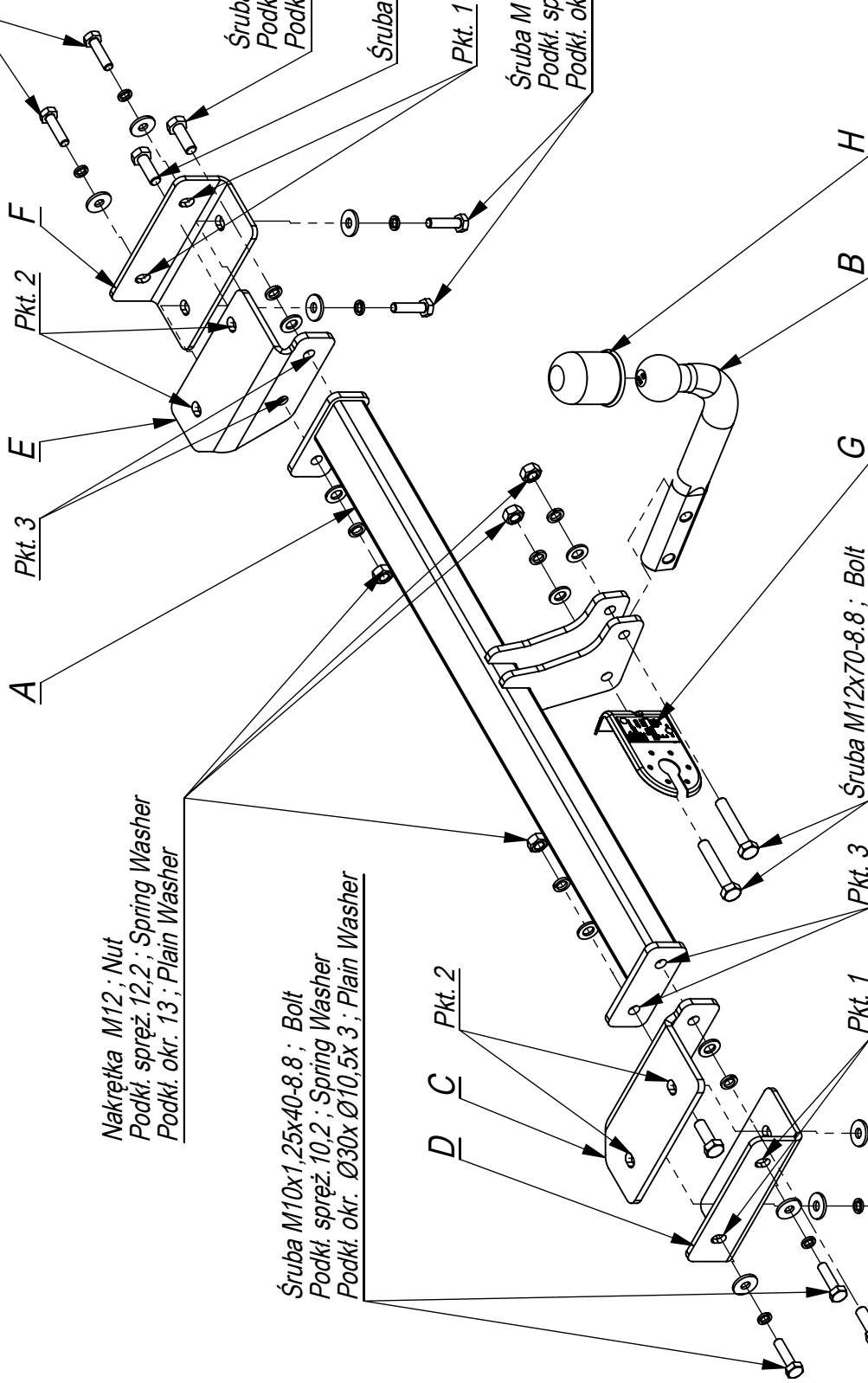

Nakrętka M12 ; Nut  
Podkl. spręż. 12,2 ; Spring Washer  
Podkl. okr. 13 ; Plain Washer

Śruba M10x1,25x40-8.8 ; Bolt  
Podkl. spręż. 10,2 ; Spring Washer  
Podkl. okr. Ø30x Ø10,5x 3 ; Plain Washer

Śruba M12x70-8.8 ; Bolt  
Śruba M10x1,25x40-8.8 ; Bolt  
Podkl. spręż. 10,2 ; Spring Washer  
Podkl. okr. Ø30x Ø10,5x 3 ; Plain Washer

Śruba M12x35-8.8 ; Bolt  
Podkl. spręż. 12,2 ; Spring Washer  
Podkl. okr. 13 ; Plain Washer

Marka  
Hyundai ix35 od 01/10 ->

Nr katalogowy  
J/038

- Odkręcić dolną część zderzaka.
- Wykonać wycięcie w dolnej części zderzaka 60x20.
- Udrożnić technologiczne otwory z gwintami w podłużnicach.
- Przykręcić lekko do lewej podłużnicy elementy C i D śrubami M10x45x1,25 (pkt 1 i 2).
- Przykręcić lekko do prawej podłużnicy elementy E i F śrubami M10x45x1,25.
- Do elementów C i E przykręcić belkę zaczepu A śrubami M12x35 8.8.
- Dokręcić wszystkie śruby z momentem wg tabeli.
- Podłączyć instalację elektryczną.
- Przykręcić dolną część zderzaka.
- Przykręcić kulę i blachę gniazda elektrycznego śrubami M12x70 8.8 (pkt 4).

- Unscrew the lower part of the bumper.
- Cut out the fragment 60x20 in the lower part of the bumper.
- The technological holes with threads in the metal clamps make permeable.
- Screw slightly the elements C and D to the left metal clamp with bolts M10x45x1,25 (point 1 and 2).
- Screw the elements E and F to the right metal clamp with bolts M10x45x1,25 8.8.
- Screw the main bar A to the elements C and E with bolts M12x35 8.8.
- Tighten all the bolts according to the torque setting- see the table.
- Connect the electric wires.
- Screw the lower part of the bumper.
- Fix the ball and electric plate with bolts M12x70 8.8 (point 4).

- Dévisser la partie basse de pare-chocs.
- Ouvrir la partie basse de pare-chocs de 60x20.
- Déboucher les trous technologiques avec le filetage dans les longerons.
- Visser légèrement les éléments C et D à la longeron gauche à l'aide des boulons M10x40x1,25 (point 1 et 2).
- Visser légèrement les éléments E et F à la longeron droite à l'aide des boulons M10x40x1,25 8.8.
- Visser la poutre du crabot A aux éléments C et E à l'aide des boulons M12x35 8.8.
- Serrer tous les boulons avec un couple de serrage selon tableau.
- Raccorder le circuit électrique.
- Serrer la partie basse de pare-chocs.
- Visser le crochet d'attelage et socle de prise électrique par les boulons M12x70 8.8 (point 4).

