



04/2007 -

JEEP WRANGLER

Cat. No. **J/028**

EKG/ONZ

nr.: 10/09

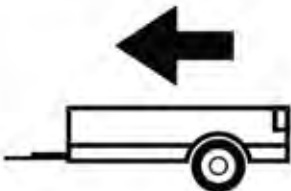

3500Kg



350Kg

D = 15,33kN

$$D \text{ (kN)} = \frac{\text{MAX kg} \times \text{MAX kg}}{\text{MAX kg} + \text{MAX kg}} \times 0,00981$$



IMIOLA HAK-POL

96-111 KOWIESY, CHOJNATA 23A, POLAND

tel. +48 46 831 73 31, fax +48 831 74 29

e-mail: office@imiola.pl, www.imiola.pl

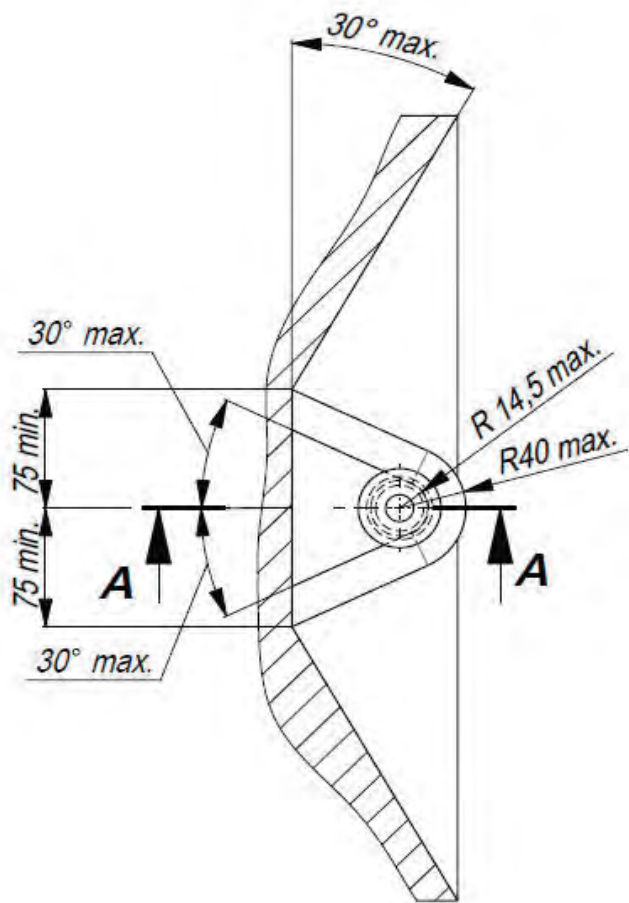

PRZEKRÓJ A-A

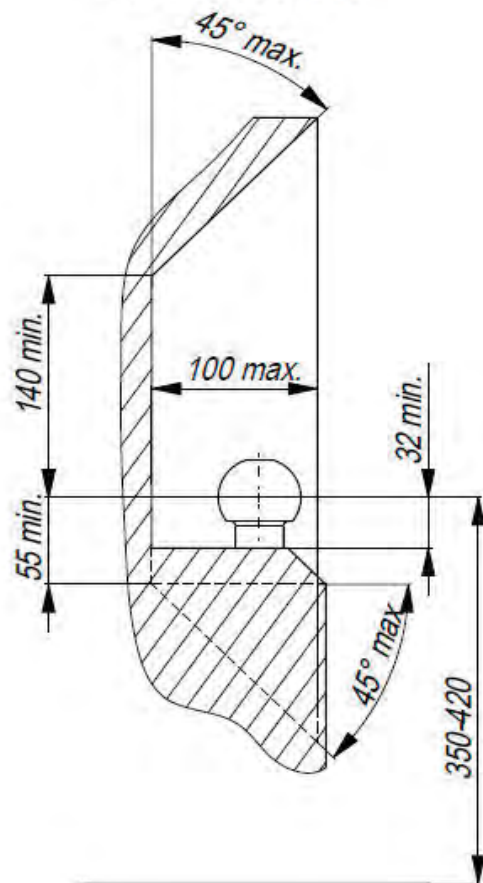

PL Należy zagwarantować przestrzeń swobodną według załącznika VII, rysunek 25a/b Regulaminu EKG ONZ 55.01 przy dopuszczalnym ciężarze całkowitym pojazdu.

F L'espace libre doit être garanti conformément à l'annexe VII, illustration de la réglementation 55.01 CE pour un poids total en charge autorisé du véhicule.

GB The clearance specified in appendix VII, diagram 25a/b of Regulation No. 55.01 UN EU must be guaranteed at laden weight of the vehicle.

D Der Freiraum nach Anhang VII, Abbildung 25a/b der Vorschriften 55.01 EG ist zu gewährleisten bei zulässigem Gesamtgewicht des Fahrzeuges

Moment skracający dla śrub i nakrętek (8.8)
Torque settings for nuts and bolts (8.8)

M8	25Nm
M10	55Nm
M12	85Nm
M14	135Nm
M16	195Nm

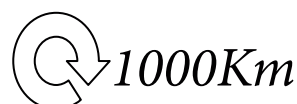

Nakrętka M12 ; Nut
 Podkł. spręż. 12,2 ; Spring Washer
 Podkł. okr. Ø36xØ13x3 ; Plain Washer

Nakrętka M12 ; Nut
 Podkł. spręż. 12,2 ; Spring Washer
 Podkł. okr. 13 ; Plain Washer

Śruba M12x120-8.8 ; Bolt
 Podkł. okr. 13 ; Plain Washer

Śruba M12x70-8.8 ; Bolt

Śruba M12x120-8.8 ; Bolt
 Podkł. okr. 13 ; Plain Washer

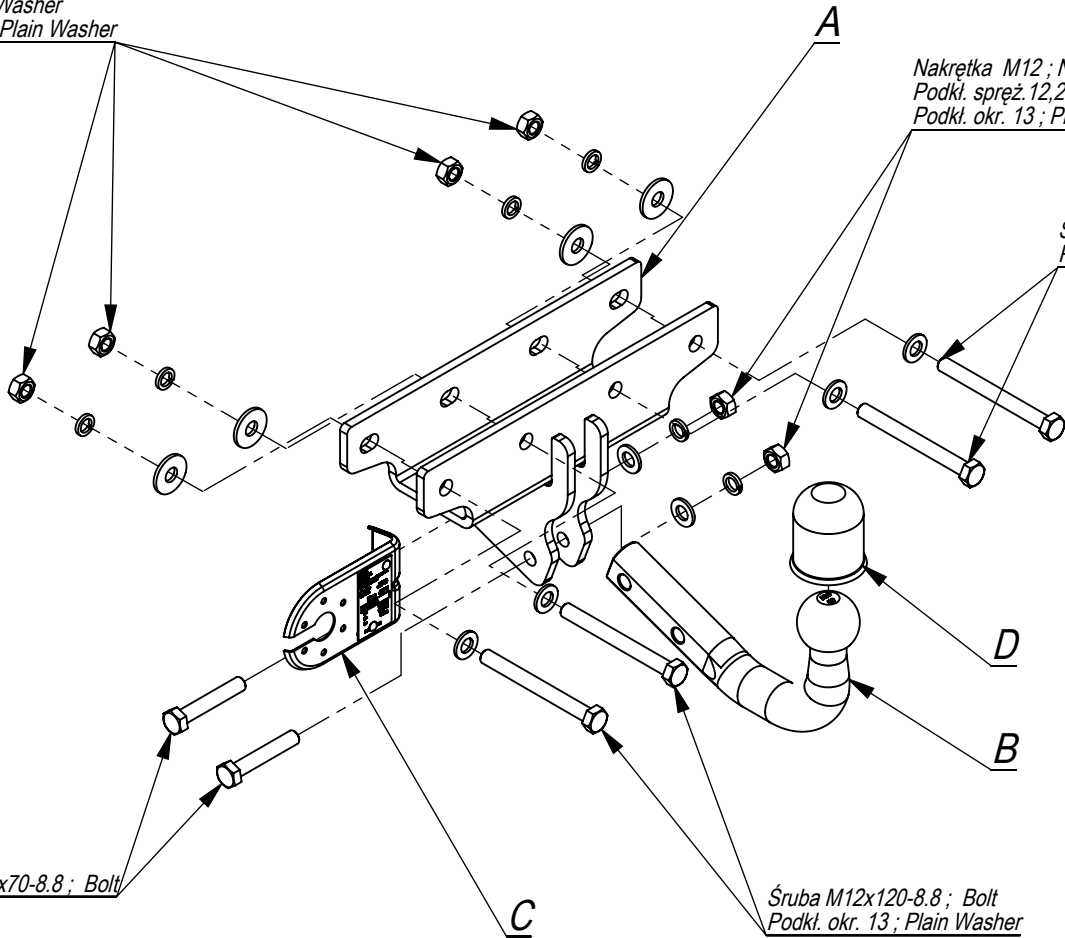

	A	x1		M12x120	4
				M12x70	2
	B	x1		M12	6
	C	x1		Ø36xØ13x3	4
	C	x1		13	6
				12,2	6

Nakrętka M12; Nut
Podkl. spręż. 12,2; Spring Washer
Podkl. okr. 13; Plain Washer

Nakrętka M12; Nut
Podkl. spręż. 12,2; Spring Washer
Podkl. okr. 13; Plain Washer

Śruba M12x120-8.8; Bolt
Podkl. okr. 13; Plain Washer

Śruba M12x120-8.8; Bolt
Podkl. okr. 13; Plain Washer

Śruba M12x70-8.8; Bolt

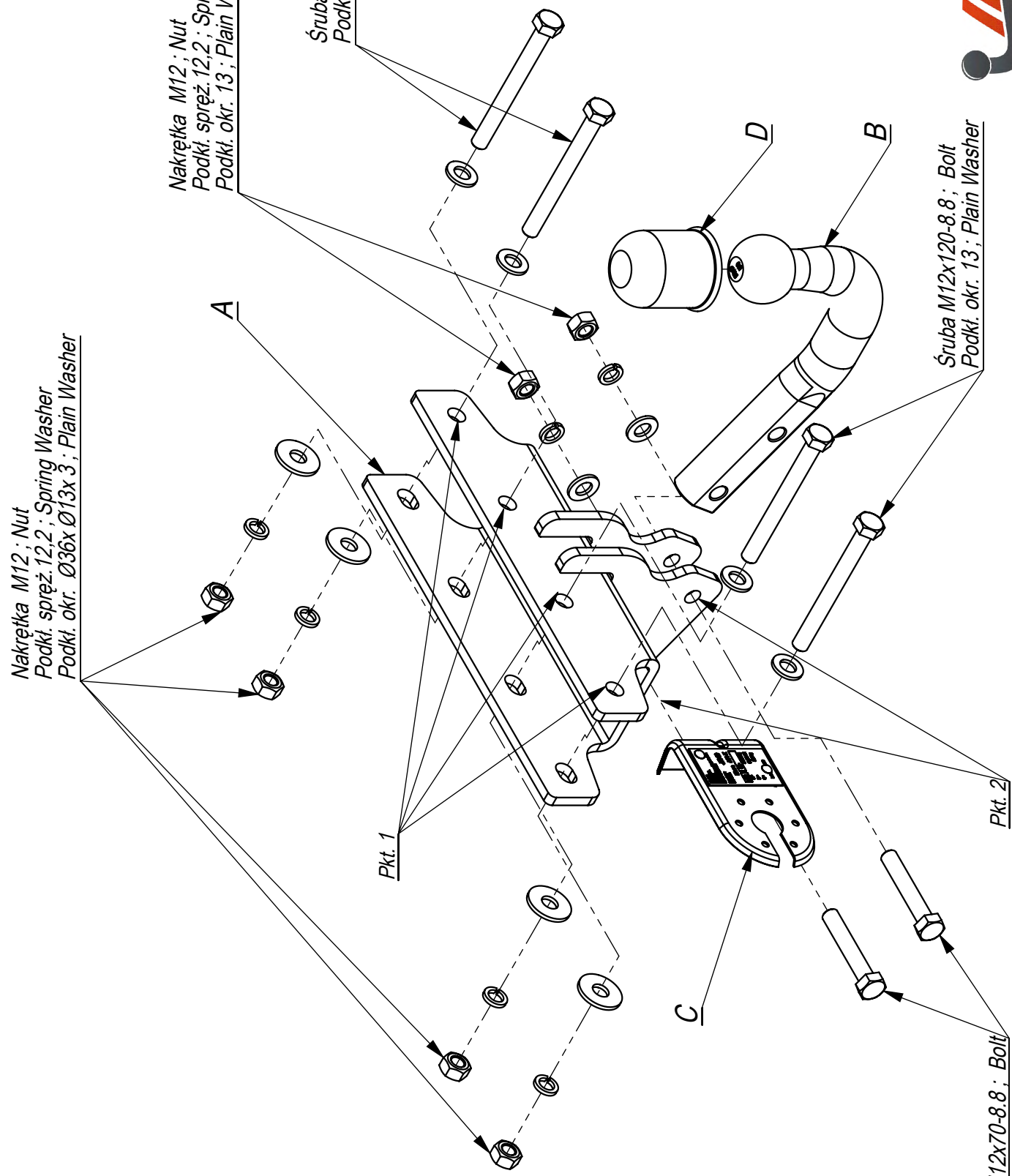

Pkt. 1

Pkt. 2



Nr katalogowy J/028
Marka Jeep Wrangler
od 2007 ->

96-111 Kowiesy, Chojnata 23 A
tel. +48 46 831 73 31

- Odkręcić zderzak.
- Przyłożyć zaczep do belki poprzecznej w tylnej części samochodu i poprzez technologiczne otwory skręcić śrubami M12x120 8.8.
- Dokręcić wszystkie śruby z momentem według tabeli.
- Przykręcić zderzak.
- Przykręcić kulę i blachę gniazda elektrycznego.
- Podłączyć instalację elektryczną.

- Unscrew the bumper.
- Put the tow bar to the cross bar in the rear part of the car and screw through the technological holes with bolts M12x120 8.8.
- Tighten all the bolts according to the torque setting- see the table.
- Screw the bumper.
- Fix the ball and electric plate.
- Connect the electric wires.

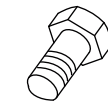
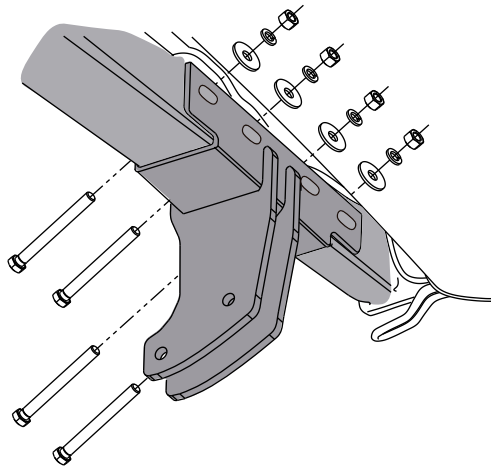
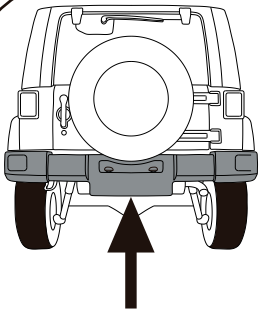
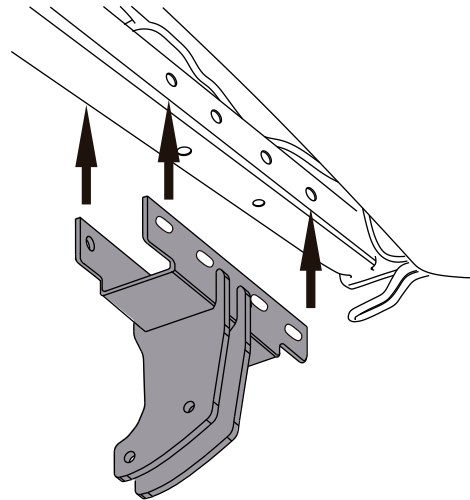
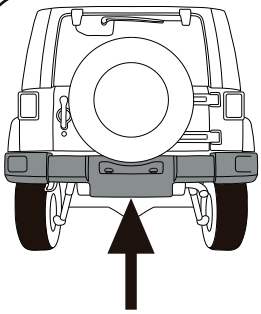
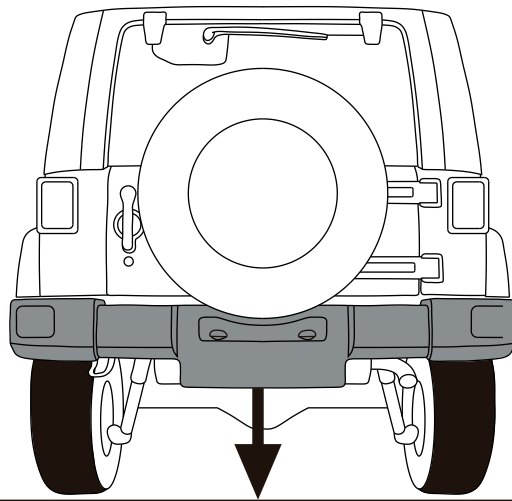

M12x120 x4



M12 x4



M12 x4



M12 x4

